

With motorized trolley-ST

This can be combined with a 4-point or 6-point pushbutton and used as a motorized trolley or overhead traveling crane.

Dimensions

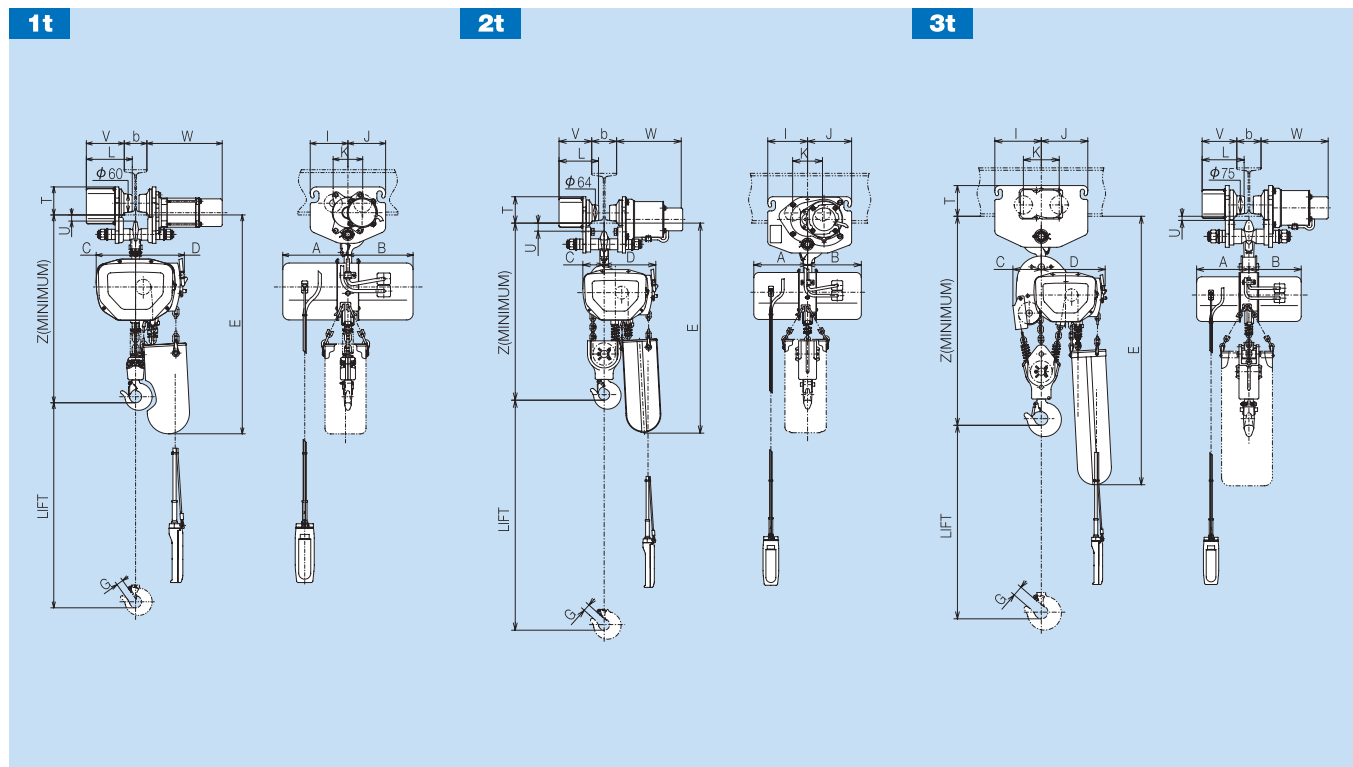

Specifications table

Chain Hoist Model Name	1S(H)	1SN(H)	2S(H)	2SN(H)	3S(H)	
Trolley Type	1ST		2ST		3ST	
Rated Load (kg)	1,000		2,000		3,000	
Dimensions (mm)	Z	578	578	700	700	852
	A	216	216	216	216	216
	B	216	246	216	246	216
	C	135	135	90	90	125
	D, D'(CE)	170	170	215	215	270
	E	730	730	772(842)		900(1,115)
	G	23	23	26	26	42
	I		125		160	192
	J		125		177	192
	K		98		120	148
	L		156		163	180
	T		101		119	140
	U		18		19	5
	V		130		135	145
W		255		270	280	
Min. Curve Radius (m)		1.8		2.5	3.0	
Applicable Beam Width b (mm)		75-100		100-150	100-150	
Approx. Weight (kg)		60(65)		86(96)	91(101)	109(120)

All dimensions and specifications are subject to change without notice.