

Suspension Hoist

■ 0.5ton
■ 1ton

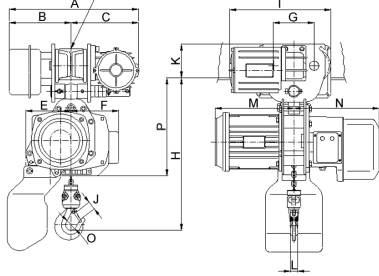

■ 2 ton

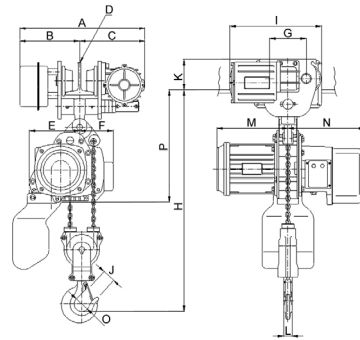

■ 2.8 ton

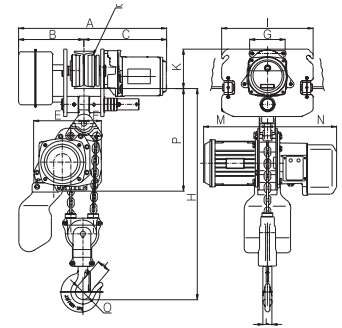

■ SPECIFICATIONS / DIMENSIONS

Model		LTHM-0.49S	LTUM-1S	LTUM-2W	LTHM-1S	LTHM-2W	LDSM-1S	LDSM-2W	LDSM-28W	LTDM-1S	LTDM-2W	
Standard Load(TON)		0.49	1	2	1	2	1	2	2.8	1	2	
Test Load(TON)		0.625	1.25	2.5	1.25	2.5	1.25	2.5	3.5	1.25	2.5	
Standard Lift(M)		4	4	4	4	4	4	4	4	4	4	
Dimension (mm)	A	423.5	423.5	454	423.5	454	423.5	454	584.5	423.5	454	
	B	207	207	222.5	207	222.5	207	222.5	258	207	222.5	
	C	242	242	257	242	257	242	257	326.5	242	257	
	D	Height	100	100	125	100	125	100	125	125	100	125
		Width	75~125	75~125	100~150	75~125	100~150	75~125	100~150	100~150	75~125	100~150
	E	145	145	181	145	181	145	181	181	181	181	
	F	191	191	155	191	155	191	155	155	155	155	
	G	130	130	130	130	130	130	130	140	130	130	
	H (min)	425	446	650	446	640	446	640	655	446	640	
	I	370	370	370	370	370	370	370	370	370	370	
	J	25	25	40	25	40	25	40	53	25	40	
	K	110	110	110	110	110	110	110	148	110	110	
	L	24	24	30	24	30	24	30	35	24	30	
	M	255	255	255	255	255	255	255	255	255	255	
	N	273	273	273	273	273	273	273	273	273	273	
O	35	35	53.5	35	53.5	35	53.5	60	35	53.5		
P	342	342	409	342	409	342	409	416	342	409		
Traversing	motor (kw × p)	High	0.3	0.3	0.3	0.3	0.3	0.3	0.75	0.3	0.3	
		Dual (high)	0.3/0.15	0.3/0.15	0.3/0.15	0.3/0.15	0.3/0.15	0.3/0.15	0.3/0.15	0.75	0.3/0.15	0.3/0.15
	Speed (M/min)	Low	50Hz	15.6	15.6	15.6	15.6	15.6	15.6	16	15.6	15.6
		High	60Hz	18.8	18.8	18.8	18.8	18.8	18.8	20	18.8	18.8
		Dual (high)	50Hz	15.7/3.8	15.7/3.8	15.7/3.8	15.7/3.8	15.7/3.8	15.7/3.8	15.7/3.8	—	15.7/3.8
60Hz	18.8/4.6		18.8/4.6	18.8/4.6	18.8/4.6	18.8/4.6	18.8/4.6	18.8/4.6	—	18.8/4.6	18.8/4.6	
Net Weight(kg)		78	79	92	79	92	80	94	102	84	98	
—		—					—			—		