

YWZ SERIE

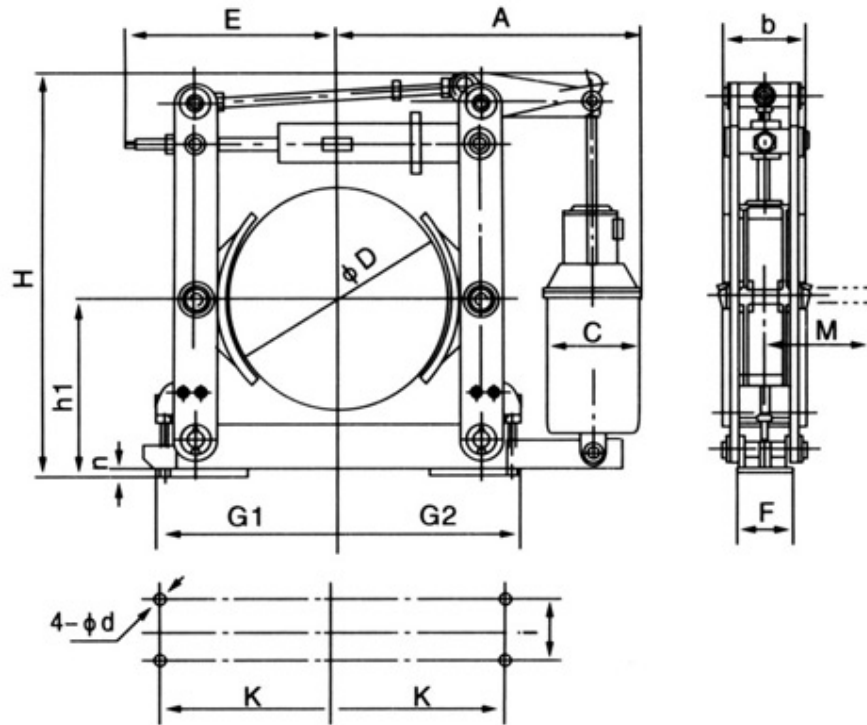

Type	匹配推动器	制动力矩N.M	退矩	b	C	D	d	F	G1	G2	H	h1	i	K	M
YWZ-100/18	MYT1-18ZB/2	40	0.6	70	137	100	13	75	125	125	384	100	40	110	138
YWZ-150/25	MYT1-25ZB/4	100	0.6	90	154	150	17	100	170	170	437	140	60	150	138
YWZ-200/25	MYT1-25ZB/4	200	0.7	90	154	200	17	100	195	195	440	170	60	175	156
YWZ-300/25	MYT1-25ZC/4	320	0.7	140	154	300	22	130	280	280	692	240	80	250	200
YWZ-300/45	MYT1-45Z/5	630	0.7	140	178	300	22	130	280	280	600	240	80	250	200
YWZ-400/45	MYT1-45Z/6	1000	0.8	180	178	400	22	180	360	360	735	320	130	325	265
YWZ-400/90	MYT1-90Z/8	1600	0.8	180	210	400	22	180	360	360	740	320	130	325	265
YWZ-400/125	MYT1-125Z/10	2200	0.8	180	254	400	22	180	360	360	850	320	130	325	271
YWZ-500/125	MYT1-125Z/10	2650	0.8	200	210	500	22	200	415	415	885	400	150	380	310
YWZ-600/90	MYT1-90Z/8	3200	0.8	240	210	600	26	220	505	520	1082	475	170	475	390
YWZ-600/180	MYT1-180Z/12	5000	0.8	240	254	600	26	220	505	520	1082	475	170	475	390
YWZ-700/180	MYT1-180Z/12	8000	0.8	280	254	700	34	270	580	600	1225	550	200	540	585
YWZ-800/180	MYT1-180Z/12	10000	0.8	320	254	800	34	320	677	697	1417	600	240	620	510
YWZ-800/230	MYT1-320Z/12	12500	0.8	320	375	800	34	320	677	697	1417	600	240	620	1100