

LT·LD Series

Suspension Hoist

■ 0.49ton
■ 1ton

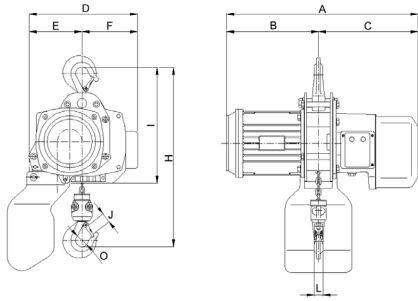

■ 2 ton
■ 2.8 ton

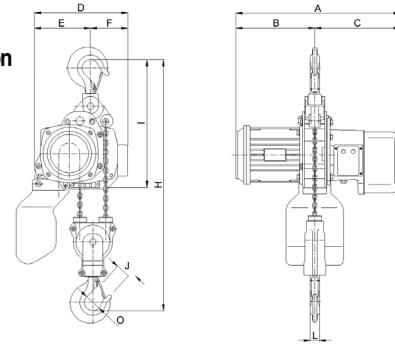

■ SPECIFICATIONS / DIMENSIONS

Model	LTH-0.49S	LTU-1S	LTU-2W	LTH-1S	LTH-2W	LDS-1S	LDS-2W	LDS-2.8W	LTD-1S	LTD-2W	
Standard Load(TON)	0.49	1	2	1	2	1	2	2.8	1	2	
Test Load(TON)	0.625	1.25	2.5	1.25	2.5	1.25	2.5	3.5	1.25	2.5	
Standard Lift(M)	4	4	4	4	4	4	4	4	4	4	
Dimension (mm)	A	528	528	528	528	528	528	528	567	567	
	B	252	252	252	252	252	252	252	252	252	
	C	273	273	273	273	273	273	273	273	273	
	D	336	336	336	336	336	336	336	336	336	
	E	145	145	181	145	181	145	181	181	145	181
	F	191	191	155	191	155	191	155	155	191	155
	H(min)	400	426	670	426	670	426	670	698	426	670
	I	326	326	438	326	438	326	438	455	326	438
	J	25	25	40	25	40	25	40	53	25	40
	L	24	24	30	24	30	24	30	35	24	30
O	35	35	53.5	35	53.5	35	53.5	60	35	53.5	
Chain Size(mm)	φ 6.3×19	φ 7.1×21	φ 7.1×21	φ 7.1×21	φ 7.1×21	φ 7.1×21	φ 7.1×21	φ 8×24	φ 7.1×21	φ 7.1×21	
Lifting Speed (m/min)	50Hz	6.7	4.5	2.3	6.9	3.4	6.9	3.4	2.5	6.8/1.7	3.4/0.85
	60Hz	8.0	5.4	2.7	8.2	4.1	8.2	4.1	3.1	8.2/2.05	4.1/1
motor(kw×p)	0.8	1.2	1.2	1.8	1.8	1.8	1.8	2.0	2.0/0.5	2.0/0.5	
Net Weight(kg)	50	51	62	51	62	53	64	74	56	68	
Brake System	Self Brake					Self Brake+Mechanical Brake			D.C Brake		